

## FULLVIEW RECTANGLE DIRECT VENT GAS FIREPLACE HEATER

### Model FV-41M (MODERN)

### OWNER'S MANUAL

DOCUMENT NO. FV41-MODERN-OM-0511



**NATIONAL FIREPLACE INSTITUTE**  
**NFI**  
**CERTIFIED**  
[www.nficertified.org](http://www.nficertified.org)

We recommend that our gas hearth products be installed and serviced by professionals who are certified in the U.S. by the National Fireplace Institute® (NFI) as NFI Gas Specialists.



**WARNING:** If the information in this manual is not followed exactly, a fire or explosion may result causing property damage, personal injury or loss of life.

**Do not store or use gasoline or other flammable vapors and liquids in the vicinity of this or any other appliance.**

#### WHAT TO DO IF YOU SMELL GAS

- Open windows.
- Do not touch electrical switches.
- Do not try to light any appliance.
- Extinguish any open flame.
- Do not use the phone in your building.
- Immediately call your gas supplier from a neighbor's phone. Follow the gas supplier's instructions.
- If you cannot reach your gas supplier, call the fire department.
- Installation and service must be performed by a qualified installer, service agency or the gas supplier.

**AVERTISSEMENT :** Assurez-vous de bien suivre les instructions donné dans cette notice pour réduire au minimum le risque d'incendie ou pour éviter tout dommage matériel, toute blessure ou la mort.

- Ne pas entreposer ni utiliser d'essence ni d'autres vapeurs ou liquides inflammables dans le voisinage de cet appareil ou de tout autre appareil.
- **QUE FAIRE SI VOUS SENTEZ UNE ODEUR DE GAZ:**
- Ne pas tenter d'allumer d'appareil.
- Ne touchez à aucun interrupteur. Ne pas vous servir des téléphones se trouvant dans le bâtiment où vous vous trouvez.
- Appelez immédiatement votre fournisseur de gaz depuis un voisin. Suivez les instructions du fournisseur.
- Si vous ne pouvez rejoindre le fournisseur de gaz, appelez le service des incendies.
- L'installation et service doit être exécuté par un qualifié installer, agence de service ou le fournisseur de gaz.

#### WARNING

Do NOT use this appliance if any part has been under water. Immediately call a qualified service technician to inspect the appliance and to replace any part of the control system and any gas control, which has been under water.

**INSTALLER:** Leave this manual with the appliance.

**CONSUMER:** Retain this manual for future reference.

**INSTALLATEUR :** Laissez cette notice avec l'appareil.

**CONSOMMATEUR :** Conservez cette notice pour consultation ultérieure.



**WARNING**

HOT GLASS WILL CAUSE BURNS.  
DO NOT TOUCH GLASS UNTIL COOLED.  
NEVER ALLOW CHILDREN TO TOUCH GLASS.



**AVERTISSEMENT**

Une surface vitrée chaude peut causer des brûlures.  
Laisser refroidir la surface vitrée avant d'y toucher.  
Ne permettez jamais à un enfant de toucher la surface vitrée.

## Table of Contents

SAFETY AND WARNING INFORMATION .....	3
SPECIFICATIONS .....	5
CONGRATULATIONS .....	6
BUILDING PERMIT AND INSTALLATION INSPECTION APPROVAL REQUIREMENTS .....	6
BEFORE YOU BEGIN.....	7
Remote Control Transmitter Functions .....	7
REMOTE TRANSMITTER OPERATING INSTRUCTIONS.....	8
TO TURN ON THE APPLIANCE .....	8
TO TURN OFF THE APPLIANCE, press the ON/OFF button.....	8
MODE KEY.....	8
TEMPERATURE INDICATOR (°F OR °C).....	9
KEY LOCK FUNCTION.....	9
LOW BATTERY POWER DETECTION.....	9
OPERATING DURING POWER OUTAGES .....	9
“FIRST TIME” PILOT LIGHTING INSTRUCTIONS .....	10
INITIALIZING THE REMOTE CONTROL SYSTEM .....	10
IPI/STANDING PILOT SYSTEM INFORMATION.....	11
FV-41 DOOR REMOVAL AND INSTALLATION.....	12
FV-41-M BURNER MEDIA INSTALLATION INSTRUCTIONS.....	13
FLAME APPEARANCE ADJUSTMENT.....	13
MENDOTA WARRANTY QUALIFICATION & SERVICE REFERENCE FORM.....	<b>ERROR! BOOKMARK NOT DEFINED.</b>
MENDOTA EXTENDED LIFETIME PROTECTION AND LIMITED WARRANTY .....	14

## **SAFETY AND WARNING INFORMATION**

### **FOR YOUR SAFETY**

A qualified installer, service agency, or the gas supplier must perform installation and service.

Do not store or use gasoline or other flammable vapors and liquids in the vicinity of this or any other appliance.

### **WARNING**

Do not operate this appliance with the glass removed, cracked or broken. A licensed or qualified person should do replacement of glass.

AVERTISSEMENT. Ne pas utiliser l'appareil si le panneau frontal en verre n'est pas en place, est craqué ou brisé. Confiez le remplacement du panneau à un technicien agréé.

### **WARNING**

Mendota gas fireplaces are heat producing appliances. Do not burn wood, paper or other materials in this fireplace. This fireplace is designed as a supplement heat source. It is advisable to have an alternative primary heat supply.

In the Commonwealth of Massachusetts:

- Installation must be performed by a licensed plumber or gas fitter;
- A CO detector shall be installed in the room where the appliance is installed.

**WARNING:** Improper installation, adjustment, alteration, service or maintenance can cause injury or property damage. Refer to this manual. For assistance or additional information consult a qualified installer, service agency or the gas supplier.

This appliance may be installed in an aftermarket permanently located, manufactured (mobile) home (USA Only), where not prohibited by local codes.

This appliance is only for use with the type(s) of gas indicated on the rating plate. This appliance is not convertible for use with other gases, unless a certified kit is used.

Cet appareil peut être installé dans un maison préfabriquée (mobile) déjà installée à demeure si les règlements locaux le permettent.

Cet appareil doit être utilisé uniquement avec les types de gaz indiqués sur la plaque signalétique. Ne pas l'utiliser avec d'autres gaz sauf si un kit de conversion certifié est installé.

The installation must conform with local codes or, in the absence of local codes, with the current National Fuel Gas Code, ANSI Z223.1 (NFPA 54) or CAN/CGA B149.1 Installation Code.

Installer l'appareil selon les codes ou règlements locaux, ou, en l'absence de tels règlements, selon les Codes d'installation CAN/CGA-B149.

**READ and UNDERSTAND** all instructions carefully before starting the appliance. **FAILURE TO FOLLOW** these instructions may result in a possible fire hazard and will void the warranty.

Any safety screen or guard removed for servicing must be replaced before operating this appliance. Tout écran ou protecteur retiré pour permettre l'entretien de l'appareil doit être remis en place avant de mettre l'appareil en marche.

### **THIS UNIT IS NOT FOR USE WITH SOLID FUEL.**

Installation and repair should be **PERFORMED** by a qualified service person. The appliance and venting system should be **INSPECTED** before initial use and at least annually by a professional service person. More frequent cleaning may be required due to excessive lint from carpeting, bedding, material, etc. It is **IMPERATIVE** that the unit's control compartment, burners, and circulating air passageways **ARE KEPT CLEAN** to provide for adequate combustion and ventilation air.

L'installation et la réparation devrait être confiées à un technicien qualifié. L'appareil devrait faire l'objet d'une inspection par un technicien professionnel avant d'être utilisé et au moins une fois l'an par la suite. Des nettoyages plus fréquents peuvent être nécessaires si les tapis, la literie, et cetera produisent une quantité importante de poussière. Il est essentiel que les compartiments abritant les commandes, les brûleurs et les conduits de circulation d'air de l'appareil soient tenus propres.

Always **KEEP** the appliance clear and free from combustible materials, gasoline, and other flammable vapors and liquids.

**NEVER OBSTRUCT** the flow of combustion and ventilation air. Keep the front of the appliance **CLEAR** of all obstacles and materials for servicing and proper operation.

Due to high temperature, the appliance should be **LOCATED** out of traffic areas and away from furniture and draperies. En raison des températures élevées, l'appareil devrait être installé dans un endroit où il y a peu de circulation et loin du mobilier et des tentures.

Clothing or flammable material **SHOULD NOT BE PLACED** on or near the appliance. On ne devrait pas placer de vêtements ni d'autres matières inflammables sur l'appareil ni à proximité.

Children and adults should be **ALERTED** to the hazards of high surface temperature and should **STAY AWAY** to avoid burns or clothing ignition. Les enfants et les adultes devraient être informés des dangers que posent les températures de surface élevées et se tenir à distance afin d'éviter des brûlures ou que leurs vêtements ne s'enflamment.

Young children should be **CAREFULLY SUPERVISED** when they are in the same room as the appliance. Toddlers, young children and others may be susceptible to accidental contact burns. A physical barrier is recommended if there are at risk individuals in the house. To restrict access to a fireplace or stove, install an adjustable safety gate to keep toddlers, young children and other at risk individuals out of the room and away from hot surfaces. "Les jeunes enfants devraient être surveillés étroitement lorsqu'ils se trouvent dans la même pièce que l'appareil. Les tout petits, les jeunes enfants ou les adultes peuvent subir des brûlures s'ils viennent en contact avec la surface chaude. Il est recommandé d'installer une barrière physique si des personnes à risques habitent la maison. Pour empêcher l'accès à un foyer ou à un poêle, installez une barrière de sécurité; cette mesure empêchera les tout petits, les jeunes enfants et toute autre personne à risque d'avoir accès à la pièce et aux surfaces chaudes.

These units **MUST** use one of the vent systems described in the Installing Your Fireplace section of the Installers Guide. **NO OTHER** vent systems or components **MAY BE USED**.

This gas fireplace and vent assembly **MUST** be vented directly to the outside and **MUST NEVER** be attached to a chimney serving a separate solid fuel-burning appliance. Each gas appliance **MUST USE** a separate vent system. Common vent systems are **PROHIBITED**.

If the vent-air intake system is disassembled for any reason, reinstall per the instructions provided for the initial installation.

The vent system assembly for this fireplace must be periodically examined by a qualified service agency.

**INSPECT** the external vent cap on regular basis to make sure that no debris is interfering with the airflow. The flow of combustion and ventilation air not to be obstructed

DO NOT abuse the glass door by striking the glass, slamming the door shut, etc.

Use only authorized parts and materials obtained from Johnson Gas Appliance Company when replacing defective or damaged glass.

**DO NOT USE** abrasive cleaners on the glass door assembly. **DO NOT ATTEMPT** to clean the glass door when it is hot.

Turn off the gas before servicing this appliance. It is recommended that a qualified service technician perform an appliance check-up at the beginning of each heating season.

**DO NOT** place furniture or any other combustible household objects within 36 inches of the fireplace front.

**SPECIFICATIONS**

**MODEL FV41-M**

**High Fire - Adjustable to - Low Fire**

BTUH. (MODEL FV41-M)	NAT. GAS	29,000	18,000
BTUH. (MODEL FV41-M)	LP GAS	29,000	22,000



**NOTE: LPG CONVERSION KIT, #New #, MUST BE PURCHASED SEPARATELY TO CONVERT TO BURN LPG IN THIS FIREPLACE.**

MAIN ORIFICE [0-2000ft (610 m)]: #38 NAT. GAS, #52 LP  
 EFFICIENCY RATINGS: ..... A.F.U.E. 74.7% and CSA P4.1-02 Fireplace Efficiency (FE) 80.24%  
 CO-AXIAL DIRECT VENT FLUE: ..... 5" INNER, 8" OUTER  
 TOTAL WEIGHT: ..... 225 POUNDS  
 SAFETY: ..... AGA/CECERTIFIED IPI AUTO ELECTRONIC IGNITION SYSTEM  
 ACTIVATED WITH THERMOSTATIC REMOTE CONTROL.

**APPLIANCE CERTIFICATION AND TESTING AGENCY**

INTERTEK TESTING SERVICES, ICBO#AA647-4

Certified under ANSI Z21.88 (2009) • CSA 2-33 (2009) "Vented Gas Fireplace Heaters" not for use with solid fuel. Approved for bedroom installations and mobile homes. UL307B approved for "mobile homes, after first sale of home, not for recreational vehicles."

**GAS REQUIREMENTS** ..... **SUPPLY PRESSURE:** GAS INLET: 1/2" N.P.T.  
 NAT. GAS: **7" W.C.** (5" W.C. MIN., 11" W.C. MAX.)  
 L.P. GAS: **11.0" W.C.** (11" W.C. MIN., 13" W.C. MAX.)

**ELECTRICAL REQUIREMENTS** ..... 115 VOLT, LESS THAN 1.5 amps (for blower operation only)

**APPROVED VENT SYSTEMS** ..... DURAVENT, SELKIRK, AMERIVENT, SECURITY

**MINIMUM CLEARANCES TO COMBUSTIBLE CONSTRUCTION**

UNIT TO FLOOR	0in. (0mm)	GLASS EDGE TO ADJACENT SIDEWALL	18in. (457 mm)
UNIT TO ENCLOSURE SIDEWALL	1/2in. (13mm)	VENT PIPE TOP TO COMBUSTIBLES	2in. (51mm)
UNIT TO ENCLOSURE BACK WALL	1/2in. (13mm)	VENT PIPE SIDES TO COMBUSTIBLES	1in. (25mm)
UNIT BOTTOM TO ENCLOSURE CEILING	48-1/2in. (123 cm)	VENT PIPE BOTTOM TO COMBUSTIBLES	1in. (25mm)
UNIT BOTTOM TO ROOM CEILING	72 in. (1829 mm)		
8" MANTLE ABOVE DISCHARGE AIR OPENING	18 in. (457 mm)		

**MINIMUM COMBUSTIBLE ROUGH FRAMING DIMENSIONS**

WIDTH = 42-1/2" (109cm)      HEIGHT = 47" (119cm)      DEPTH = 19-3/16" (49cm)

THIS FIREPLACE INCLUDES A SEALED COMBUSTION SYSTEM, NEO-CERAM GLASS, ELECTRONIC IGNITION SYSTEM, AGA CERTIFIED SAFETY SYSTEM, ACCENT LIGHT and THERMOSTATIC REMOTE CONTROL.

**OPTIONS:** BLACK, VINTAGE IRON, SWEDISH NICKEL, ANTIQUE GOLD, ANTIQUE COPPER STEEL DOORS, STAINED GLASS FRONT, BOULEVARD DOORS, SERENADE, TRADITIONS AND PORTRAIT TRIMS and other accessories. Visit [www.mendotahearth.com](http://www.mendotahearth.com) for all current offerings.

**CAUTION**  
**THESE INSTRUCTIONS ARE TO REMAIN WITH THE HOMEOWNER.**

This appliance may be installed in an aftermarket, permanently located, manufactured home (USA only) or mobile home, where not prohibited by local codes.

This appliance is only for use with the type(s) of gas indicated on the rating plate.

**NOTE:** This installation must conform to local codes. In the absence of local codes, you must comply with the **National Fuel Gas Code, ANSI Z223.1-latest edition** in the U.S.A. and the Natural Gas and Propane Installation Code, **CSA B149 Installation Codes** in Canada.

**WARNING:** Do not operate this appliance with the glass removed, cracked or broken. A licensed or qualified person should do replacement of glass.

**HIGH ALTITUDE INSTALLATION INFORMATION:** Prior to installing at altitudes higher than 7500 feet, please contact the Mendota technical service department for specific venting requirements and venting restrictions.

## **CONGRATULATIONS**

You are the owner of a world-class heat producing gas direct vent sealed combustion fireplace.

This elegant, highly efficient Fireplace will be a constant source of comfort and fascination. It will be the focal point of beauty and interest in your home.

The Mendota Gas Fireplace is a true heating appliance incorporating the traditional aesthetics of fireplace fire viewing with the controllability and fuel efficiency of a home gas furnace. Of particular interest is the low fuel consumption and brilliant fire viewing afforded by the realistic Premium Fiber wood fire-like combustion system.

Carefully read the following instructions prior to actual installation. Proper Mendota Gas Fireplace installation and operation will give you years of safe, trouble free comfort and enjoyment.

If you have any questions regarding installation or operation of your Mendota Fireplace please contact your local dealer.

### **...CAUTION...**

Due to high temperatures, the Fireplace should be located out of traffic and away from furniture and draperies. Children and adults should be alerted to the hazards of high surface temperature and should stay away to avoid burns or clothing ignition. Young children should be carefully supervised when they are in the same room as the Mendota Gas Fireplace.

Clothing or other flammable material should not be placed on or near the Fireplace.

Any safety screen or guard removed for servicing an appliance must be replaced prior to operating this appliance.

The Mendota Gas Fireplace is a powerful and efficient heating unit. It has been designed as a major source of supplemental heat. As with any mechanical appliance there can be component shut downs. It is advisable to have an alternate heat supply.

Installation, repair and any adjustments to logs or burner must be done by a qualified service person. The appliance should be inspected before use and at least annually by a professional service person. More frequent cleaning may be required due to excessive lint from carpeting, bedding material, carbon build-up, etc. It is imperative that control compartments, burners and circulating air passageways of the appliance be kept clean. The burner and pilot flames and logs should be visually checked periodically.

DO NOT use this appliance if any part has been under water or exposed to moisture corrosion. Immediately call a qualified service technician to inspect the Fireplace and replace any part of the control system and any gas control, which has been under water. DO NOT use this fireplace if the burner does not light immediately. Turn unit off and call Mendota approved service person if there is any delay in burner light off.

It is Johnson Gas Appliance Company's policy that no responsibility is assumed by the Company or by any of its employees or representatives for any damages caused by an inoperable, inadequate, or unsafe condition which is the result, either directly or indirectly, of any improper operation, installation or servicing procedures.

### **Building Permit and Installation Inspection Approval Requirements**

All installations of Mendota Fireplaces and Inserts must comply with all the requirements stated in this Installation and Operating Instructions Manual. The Dealer and/or installer must also obtain all required Building Permits and Inspection Approval from the local building inspection department or the local body having jurisdiction. In order to validate warranty coverage, Mendota may require facsimile copies of the Building Permit and Inspection Approval forms. Failure to provide adequate proof that the installation conforms to all local requirements and the requirements stated in the Installation and Operating Instructions Manual will void all applicable warranty.

**INSTALLER: THESE INSTRUCTIONS ARE TO REMAIN WITH HOMEOWNER.**

**HIGH ALTITUDE INSTALLATION INFORMATION:** Prior to installing at altitudes higher than 7500, please contact the Mendota technical service department for specific venting requirements and venting restrictions.

## BEFORE YOU BEGIN

Read this entire manual before you use your new fireplace (especially the section “Safety Precautions” on page 2). Failure to follow the instructions may result in property damage, bodily injury, or even death.

## Remote Control Transmitter Functions

**NOTE:** The Wall Receiver will “beep” once every time a Remote Transmitter Key is pressed, signaling that the command has been received.

Identify the four function buttons on the Remote Transmitter:

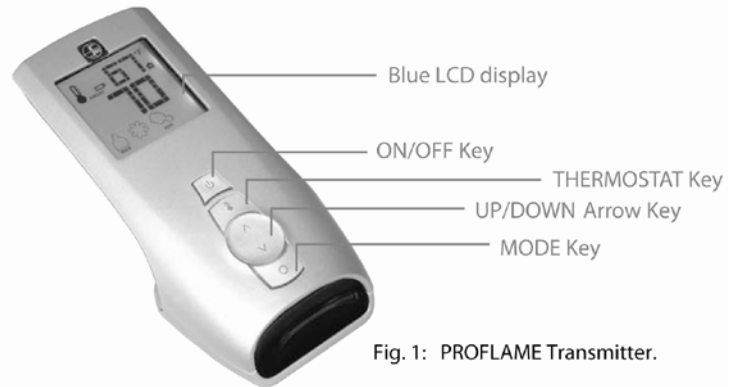

1. **ON/OFF KEY:** This button turns the system ON or OFF. When this button is pressed and the system is OFF, the pilot light will stay ON if the “Standing Pilot Switch” is in the ON position.



2. **THERMOSTAT KEY:** This button, when pressed after the ON/OFF KEY is pressed and the system is ON, will allow the selection of three modes: Manual Operation, Normal Thermostat and Smart Thermostat.



- a. **Manual Mode:** In this mode, the room temperature is ignored and the fireplace can be turned ON indefinitely. The room temperature rise has no effect on this mode. All other functions such as fan speed control, flame height control, secondary burner On/OFF control and Accent Light ON/OFF controls will be manually controllable.

- b. **Normal Thermostat:** In this mode, the fireplace will stay functioning until the room temperature increases 1°F above the Set Point Temperature. To increase the Set Point Temperature, Press the UP button until the desired temperature is displayed in the SET POINT TEMPERATURE window. The fan will turn on 5 minutes after fireplace startup and will turn off 12-1/2 minutes after the flames turn off, in this mode. The flame height can be adjusted while the fireplace is functioning, fan speed can be adjusted after 5 minutes of startup. Secondary burner can be turned On or Off at any time after startup. The Accent Light can be turned on or off any time after startup.

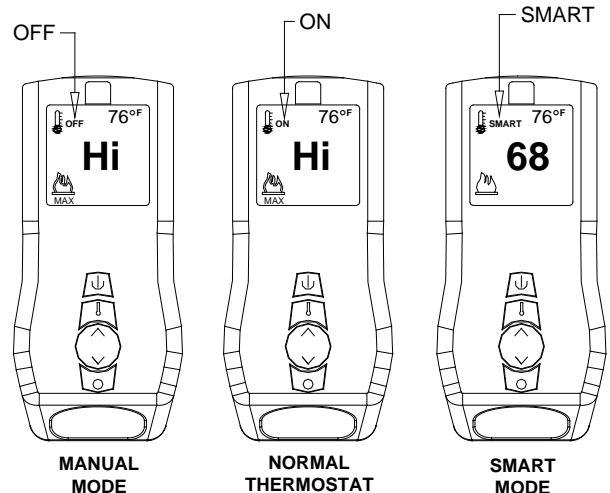

- c. **Smart Thermostat:** In this mode, all other functions except the flame height adjustment are allowed. Manual flame height adjustment is not allowed in this mode. The Smart Thermostat function adjusts the flame height in accordance to the difference between the set point temperature and the actual room temperature. As the room temperature gets closer to the set point temperature, the Smart Function automatically modulates the flame down.

3. **UP/DOWN KEY:** This key is used to increase or decrease the Set Point Temperatures, Flame Height and to toggle between Accent Light ON/OFF.

4. **MODE SELECTION KEY:** This key is used to toggle between the various function icons : Flame Height, Fan Speed, Accent Light and Secondary Burner.

**NOTE:** The Fan System is an optional accessory for this Fireplace. The Secondary Burner is NOT available for this Fireplace. Your Remote Control Transmitter may display the Fan Speed Icon, however, this function will not be available unless the Optional Fan System is purchased separately and installed. Your remote control may display the Secondary Burner Function icon but it is not available in this Fireplace.

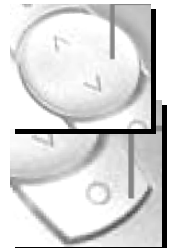

## REMOTE TRANSMITTER OPERATING INSTRUCTIONS

### TO TURN ON THE APPLIANCE:

1. Press the ON/OFF button. The transmitter display will show all active icons on the screen.
2. Select the Thermostat Mode by pressing the Thermostat Key: OFF (meaning Manual Mode), ON (meaning normal Thermostat) or Smart (meaning Smart Mode).
  - a. In OFF (Manual Mode), the appliance will ignite and start on HI.
  - b. In ON (Normal Thermostat Mode), the appliance will only ignite if the Set Temperature is greater than the Room Temperature.
  - c. In SMART (Smart Mode), the appliance will only ignite if the Set Temperature is greater than the Room Temperature.



### TO TURN OFF THE APPLIANCE, press the ON/OFF button.



#### MODE KEY

Pressing the MODE KEY toggles between the various available functions: Flame Height, Fan Speed, Aux (Accent Light) On/Off and Secondary Burner On/Off.

**Flame Height:** 6 flame height Levels are available. While the Flame Height Icon is displayed, pressing the Up or Down button once will increase or decrease the flame height by 1 of 6 increments. If the flame height is at Level 1 and the Down button is pressed, all burners will turn OFF. If in IPI mode, the pilot light will also extinguish. If in Standing Pilot Mode, the pilot light will remain ON. Note: If in SMART model, the flame height function is not available for manual adjustment. In SMART mode, the flame height regulates automatically.



FLAME HEIGHT



Flame Off

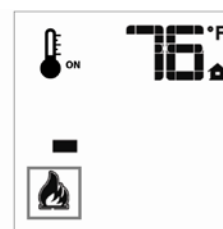

Flame Level 1

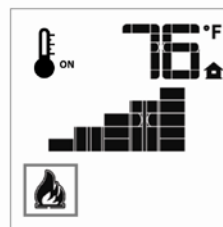

Flame level 5

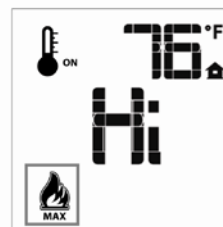

Flame Level Maximum

**Aux (Accent-Light):** This function controls the Mendota Accent Light function. Pressing the UP key in this mode will TURN ON the Accent Light and Pressing the DOWN key will TURN OFF the Accent Light. A single “beep” will confirm reception of the command. *Note:* The Accent Light Dimmer control is located adjacent to the Remote Receiver. Turn the Dimmer Control Knob to dim or brighten the Accent Light. Once you set your desired brightness level, you may use the AUX function to turn the Accent Light On or Off at that preset level.



AUX

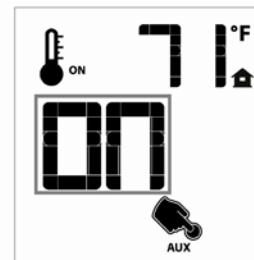

#### NOTE:

The remote control transmitter supplied with the FV41-M model Fireplace will display two additional icons when scrolling through using the MODE button. They are NOT available for this model and must be ignored. Press the MODE button to skip past these two icons to the next available icon.

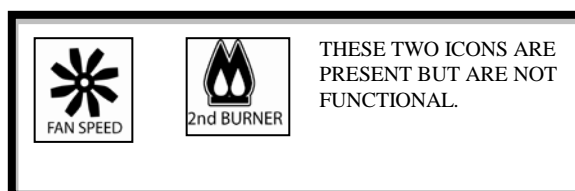

## MANUAL BYPASS OF THE REMOTE SYSTEM

If the remote transmitter is misplaced or lost, the appliance can be turned on manually by sliding the three position slider switch on the wall receiver to the ON position. This will bypass the remote control feature of the system and the appliance's main burner will turn on. The fan will run at its maximum speed and the Accent Light may turn on.

To turn off the appliance, if the remote control is misplaced or lost, slide the three position slider switch on the wall receiver to the OFF Position.

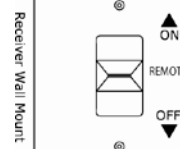

## TEMPERATURE INDICATOR (°F or °C)

1. Press the ON/OFF Key and Turn Off the Fireplace.
2. Simultaneously, Press both the MODE Key and the Thermostat Key.
3. Look at the LCD display to verify that your desired indicator (°F or °C) is being displayed. If not, repeat step 2.

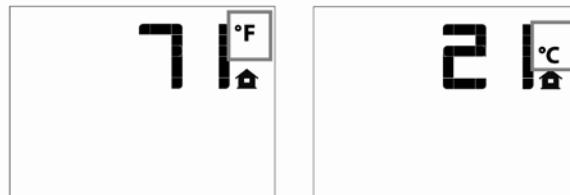

## KEY LOCK FUNCTION

To prevent unsupervised children from operating the fireplace, a KEY LOCK function is provided with this remote control system. To activate the KEY LOCK function, simultaneously press the "MODE KEY" and the "UP KEY". To deactivate the KEY LOCK function, simultaneously press the "MODE KEY" and the "UP KEY".

During KEY LOCK mode, none of the Keys will function. You must DEACTIVATE the system before you can use the Remote Transmitter.

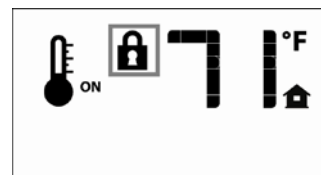

## LOW BATTERY POWER DETECTION

1. **Transmitter Batteries:** The life span of the remote control transmitter batteries depends on various factors: quality of the batteries used, the number of ignitions of the appliance, the number of changes to the room thermostat set point, etc. When the Transmitter batteries are low, a Battery Icon will appear on the LCD display of the Transmitter before all battery power is lost. When the batteries are replaced, this icon will disappear.
2. **Wall Receiver Batteries:** The life span of the wall receiver batteries depend on the quality of the batteries used and how long the batteries have been installed in the wall receiver. These batteries are only utilized during power outages. Replace these batteries every heating season even if you have not experienced any power outages. Batteries drain slowly even when not in use. This is a normal characteristic of all batteries.

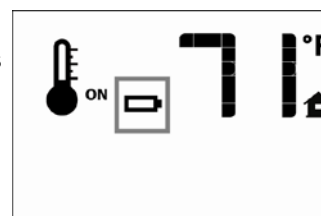

## OPERATING DURING POWER OUTAGES

This electronic ignition system utilizes the supplied 110VAC power when it is available for all functions of this system. If the AC power is interrupted during a power outage, this system utilizes the batteries (installed in the Wall Receiver) as back-up batteries. During the power outage, the appliance's burners will function. In addition, Flame Height adjustment and Secondary Burner ON/OFF functions will be available. The Fan and Accent Light, which are wholly dependent on 110VAC power, will not function.

This appliance is designed and tested to be operated during power outages. The overall efficiency of this appliance will be reduced by approximately 5% when the blower function is disabled during the power outage period.

## **“FIRST TIME” PILOT LIGHTING INSTRUCTIONS**

**IMPORTANT:** Be sure all items on "INSTALLATION CHECK OFF LIST" in the Installation Manual have been completed!

**CAUTION:** If the pilot goes out, be sure to wait a minimum of five minutes before attempting to relight the pilot.

1. Make certain that any manual gas supply shut-off valves located upstream of fireplace are open and the wall receiver and the remote control transmitter are in the "OFF" position. Make certain that the wall receiver harness is connected to the wall receiver properly.
2. Make certain that 110VAC power is connected to Electrical Junction Box on left side of Fireplace and that the Electrical Power is "ON". See Figure 28.
3. Insert Batteries in the Wall Receiver and the Remote Transmitter. Note the polarity of batteries and insert as indicated on the battery compartment covers.
4. For the "First Time Lighting", Remove the Glass Door. This is required to purge the gas line of air and to inspect the pilot lighting spark.
5. Slide the wall receiver switch to "REMOTE". Locate the "Standing Pilot ON/OFF Switch". See Figure 1. Toggle "Standing Pilot ON/OFF Switch" to "ON". You will hear a series of clicks and after a few seconds, you will hear sparking at the pilot spark electrode.
6. Allow adequate time for the air in the gas-line to purge. The control system will stop sparking after 30 seconds if the pilot light does not light. After a 30 second delay the control system will start sparking again for 30 seconds more. If the pilot light does not light after the third 30 second spark event, the system will enter "Lock-out" mode. To unlock from "Lock-out" mode, slide Wall Receiver Switch to "OFF", wait 30 seconds and slide back to "Remote". Repeat this sequence until the pilot flame lights and the pilot is burning steadily.
7. Once the pilot flame is lit and well-established, close glass door. **WARNING: NEVER IGNITE MAIN BURNERS WITH GLASS DOOR REMOVED OR OPEN. Doing so will lead to damage to pilot flame sensor and spark electrode wire leads.**
8. Slide switch on Wall Receiver to "ON". All burners should ignite and run at "high-fire". Slide Wall Receiver switch to REMOTE after 15 seconds. Burner Flames will extinguish.
9. Perform gas inlet and outlet pressure tests and leak tests on field installed gas fittings and factory installed fittings in the gas valve compartment, at this time. Note: Burners must be ON to check outlet pressures and to leak test gas train fittings upstream of main gas valve.

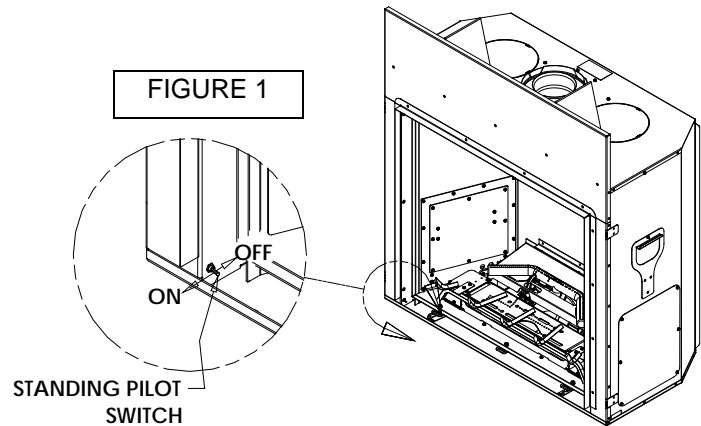

## **INITIALIZING THE REMOTE CONTROL SYSTEM**

### **(Synchronizing Receiver and Transmitter)**

1. Place 3-position slider switch in Wall Receiver in the "Remote" position.
2. Locate "PRG" key on Wall Receiver Face. Use the tip of a pen/pencil or a wire clip to push the PRG button. The receiver will beep 3 times indicating that it is ready to synchronize with a Remote Transmitter.
3. Push the "ON" key on the Remote Transmitter. The receiver will beep 4 times to indicate that the Transmitter's command is accepted and sets to the particular code of that Transmitter. The system is now initialized.

**NOTE:** Use this Synchronizing procedure every time the batteries are replaced in the Receiver or the Transmitter.

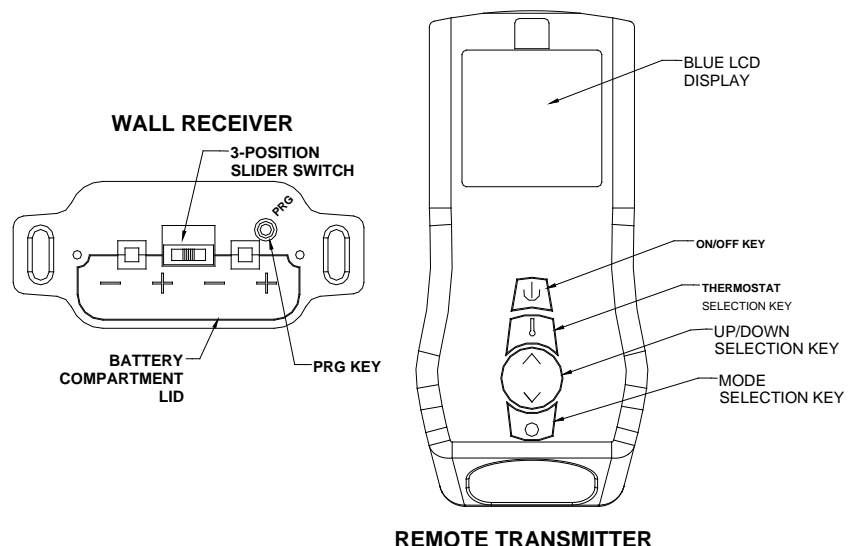

## IPI/STANDING PILOT SYSTEM INFORMATION

	REMOTE CONTROL	WALL RECEIVER
Supply voltage	4.5V (three 1.5V AAA batteries)	6.0V (four 1.5V AA batteries)
Ambient temperature ratings	32 – 122 °F (0 – 50 °C)	32 – 140 °F (0 – 60 °C)
Radio Frequency	315 MHz	315 MHz

### **ATTENTION!**

The transmitter and receiver are RADIO FREQUENCY DEVICES. Placing the receiver in or near metal may severely reduce the signal range.

- Turn off the main gas supply of the appliance during installation or maintenance of the receiver.
- Place the receiver's 3-position slider switch in the "off" position during installation or maintenance.
- Turn "off" main gas supply to the appliance prior to removing or reinserting the batteries in the receiver.
- During appliance installation/maintenance or in case of remote control malfunction, turn off electrical supply to this appliance and remove the batteries from the wall receiver battery compartment. Contact technical service.

### **Intermittent Pilot Light and Standing Pilot Light Features**

This gas fireplace is equipped with an electronic ignition System that first lights a pilot light then uses the pilot light to ignite the main burners. The pilot light can be set in the "Standing Pilot" mode to allow the pilot light to remain on indefinitely by toggling the "Standing Pilot Switch" to the ON position. If the "Standing Pilot Switch" is toggled to the OFF position, the pilot light will only light and remain ON while the main fireplace burners are operating.

**IPI Mode:** This mode turns the pilot light "OFF" when the fireplace is not functioning and only lights the pilot light automatically when a call for heat is made by the remote control.

**Standing Pilot Mode:** If the "Standing Pilot Switch" is toggled to ON, the pilot light will ignite and remain ON as long as the "Standing Pilot Light Switch" is in the ON position.

**NOTE:** Mendota Fireplaces recommends that the **Standing Pilot Mode** be used during the winter months when external temperatures fall below 50°F. This will keep the fireplace chimney heated for proper updraft during burner ignition and it will also eliminate excessive condensation of exhaust vapors on the door glass. Further, leaving the fireplace in the Standing Pilot Mode will keep the fireplace body warm and eliminate cold drafts and heat loss to the cold air that is trapped inside the firebox.

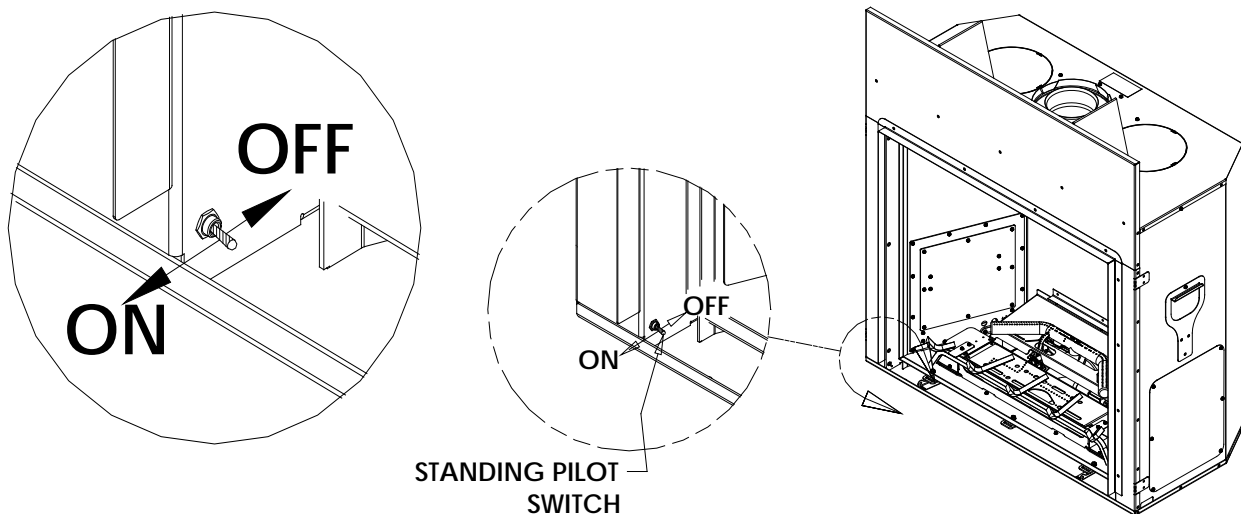

## FV-41 DOOR REMOVAL AND INSTALLATION

### TO REMOVE DOOR

1. Use the glass latch tool to disconnect the spring latches from the glass frame. Insert tool into hole in latch, pull towards you and Rotate 90 degrees to disengage top latches. Remove tool. **There are two spring latches on top of this gas fireplace.**
2. With both hands, rotate top edge of glass frame away from unit 12 inches.
3. Lift glass frame up 1 inch, at an angle, and move away from unit.
4. Door is now free from unit.

### TO REPLACE DOOR

1. With the Glass Door at a sharp angle to the firebox, line up the three bottom tabs in glass frame bottom with slots in glass clips on firebox bottom. Insert tabs into slots and center tabs in slots, left to right.
2. Center Glass Frame over Firebox; left to right.
3. After door has been placed into slots, rotate door towards firebox until gasket seal is touching the firebox frame.
4. Use the tool provided to connect the spring latches to the glass frame. Insert tool into hole in spring latch, pull latch towards you, rotate latch so the hook is facing downward then release latch to hook to door frame.
5. Door is now connected and sealed to unit.

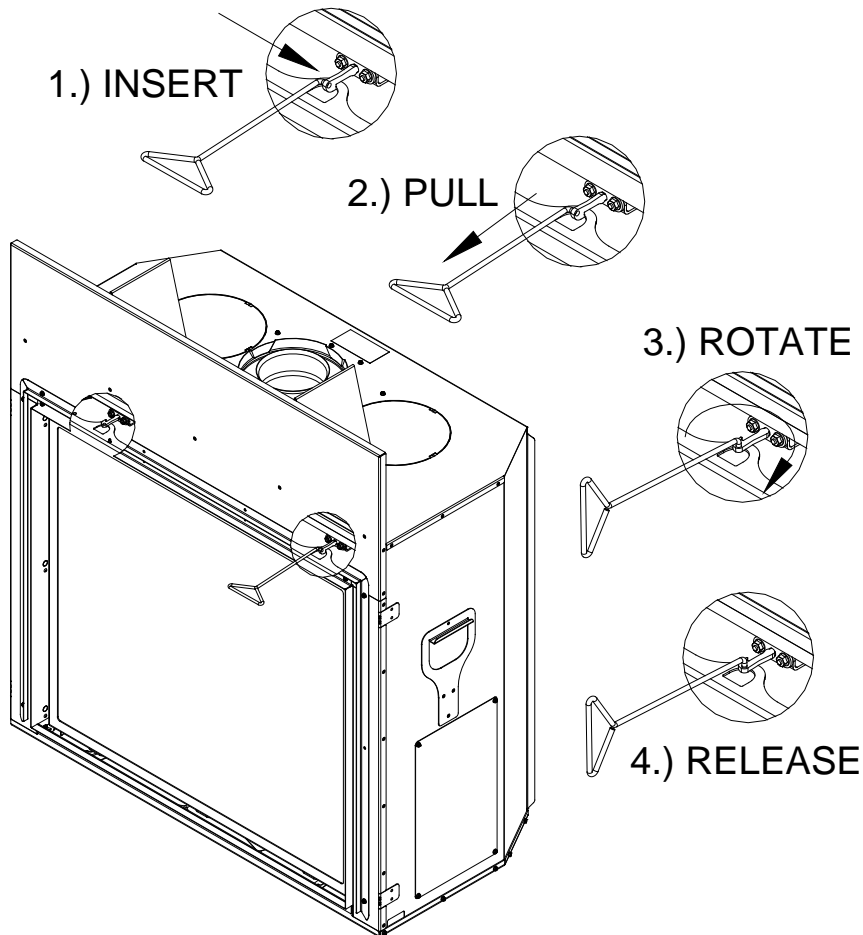

## **FV-41-M BURNER MEDIA INSTALLATION INSTRUCTIONS**

WARNING: Failure to position the parts in accordance with these diagrams or failure to use only parts specifically approved with this appliance may result in property damage or personal injury." AVERTISSEMENT. Risque de dommages ou de blessures si les pièces ne sont pas installées conformément à ces schémas et ou si des pièces autres que celles spécifiquement approuvées avec cet appareil sont utilisées.

Two media choices are available directly from Mendota for use on the FV41-M model. Select one media and purchase separately.

Media Choices:

1. Black Glossy Glass Media, 1/2" diameter, 5 lbs bag
2. Natural Rocks Fiber Media, 1"-1-1/4" diameter mixture, 70 pieces in random colors

How to install burner media properly:

1. Spread media on burner's top surface only. Do not block air slots that are in front, behind or on sides of burner.
2. Burner Media shall be only 1-layer thick and loosely spread over burner surface. DO NOT pack tightly. Allow 1/8" space between media pieces. Save extra media that is not used.



## **FLAME APPEARANCE ADJUSTMENT**

### **AIR SHUTTER ADJUSTMENTS**

Be sure burner and burner media are properly. For Natural Gas applications, leave air shutter closed fully. For LPG applications, start with air shutter open 1/4" to 3/8". After burner has been properly installed and operated for 20 minutes, small additional adjustments to the air shutter may be necessary for final flame appearance. These small shutter adjustments can be made by following these procedures:

**NOTE: Start with the burner air shutter set at 0" to 1/8" open for NG and 1/4" to 3/8" open for LPG.**

Opening the shutter will yield shorter and blue(er) flames and closing the shutter will yield taller and yellow(er) flames.

The burner air shutter adjustment lever is located inside the firebox on the left side of center.

1. Install burner media and glass frame, and burn unit for 20 minutes minimum.
2. If flame is too "blue" open Air Shutters until flames turn yellow.
3. If flames are too "orange" or are causing sooting, open Air Shutters until flames begin to turn blue.  
NOTE: If sooting does not stop, turn off fireplace & call a Mendota Service Person.

**IMPORTANT:** Try each new shutter setting for approx. 20 minutes before making additional changes.

**NOTE:** Changes in burner flame can be made by re-arranging the burner media as well. Make certain burner media is loosely spread over burner in a SINGLE layer only. DO NOT pack media tightly.

4. For NG applications, start with the burner air shutter closed to 1/8" open. For high altitude applications, air shutter may need to be open further.
5. For LPG applications, start with the burner air shutter open 1/4" to 3/8". For high altitude applications, air shutter may need to be opened further.

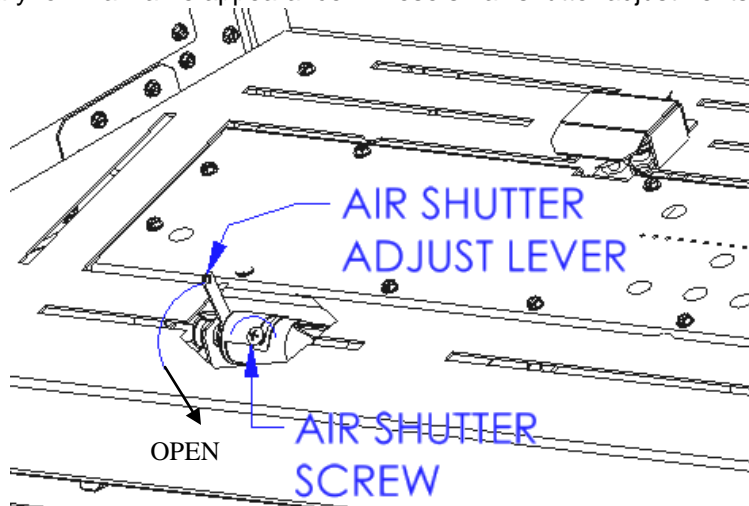

## **MENDOTA EXTENDED LIFETIME PROTECTION AND LIMITED WARRANTY** **MENDOTA FV-41 DIRECT VENT FIREPLACE**

Mendota Division of Johnson Gas Appliance Company, 520 E Avenue N.W. Cedar Rapids, Iowa 52405, extends this Extended Lifetime Protection and Limited Warranty to the original purchaser of a Mendota FV-41 Fireplace, which is limited and used under normal home conditions.

### **STANDARD WARRANTY:**

JOHNSON GAS APPLIANCE CO., MENDOTA DIVISION, WARRANTS THAT YOUR NEW MENDOTA FIREPLACE IS FREE FROM MANUFACTURING AND MATERIAL DEFECTS FOR A PERIOD OF ONE YEAR FROM THE DATE OF INSTALLATION, SUBJECT TO THE FOLLOWING CONDITIONS AND LIMITATIONS:

### **EXTENDED LIFETIME WARRANTY:**

THE HEAT EXCHANGER, BURNER TUBE COMBUSTION CHAMBER AND OUTER SHIELD OF THE MENDOTA FV-41 FIREPLACE ARE WARRANTED FOR THE LIFETIME OF THE ORIGINAL OWNER, SUBJECT TO PROOF OF PURCHASE AND THE FOLLOWING CONDITIONS AND LIMITATIONS:

- 1) This new Mendota Fireplace must be installed & serviced by a competent, authorized service contractor. It must be installed and operated at all times in accordance with the installation and operating instructions furnished with the Fireplace. All adjustments to logs, coals or burner must be made by an authorized Mendota person. Any alteration, willful abuse, accident or misuse of the product shall nullify this warranty. This warranty does not cover glass or log breakage.

This limited warranty does not cover the cost of service calls, the cost of labor to remove or install parts covered by this limited warranty, freight or other transportation expenses, which may be incurred in connection with obtaining performances under this limited warranty. The remedy for damages as the result of any defects in this product which have been warranted herein is limited to replacement parts and does not include any incidental, indirect or consequential damages or expenses sustained in connection with the product, including damages to property, except as provided by law.

- 2) This warranty is non-transferable and is made to the original retail purchaser, provided the purchase was made through an authorized Mendota dealer.

Mendota is not responsible for any damage to or malfunction of the Fireplace unless caused by a defect in material or workmanship from normal home use. Damage caused by abuse, improper installation, improper servicing, and installation by unqualified personnel or breach of conditions of this limited warranty will excuse Mendota from performance of any part of this limited warranty. Mendota has the right to investigate and inspect the exact, original Fireplace and entire installation (without any alterations or tampering) in the event a claim is made to determine whether the claimed damage or malfunction was caused by abuse, improper installation or other cause outside this warranty. Mendota is not responsible for any repairs or material purchases that have not received prior written approval from Mendota.

NOTE: Minor warping of certain parts or discoloration is normal and is not a defect covered by this warranty. Major warping of parts can be caused by over-firing of your Mendota Fireplace. Over-firing above rated nameplate specification is as contrary to the manufacturer's instructions and may void this warranty.

This warranty may not be extended by our representatives or any third party in any manner. The company neither assumes, nor authorizes any third party to assume, on its behalf, any other liabilities with respect to the sale of this Mendota product.

- 3) Mendota may at its discretion, fully discharge all obligations of this warranty by refunding the wholesale price of the defective part(s).
- 4) All other warranties - expressed or implied - with respect to the product, its components and accessories, or any obligation/liabilities on the part of the company are hereby expressly excluded. Products made by other manufacturers, sold with the Fireplace or thereafter, are not covered by this limited warranty. The use of unauthorized components will make this warranty null and void.

This warranty shall be effective only if the original purchaser of the Mendota appliance is registered with Mendota Division within thirty (30) days of the date of purchase. Such registration or the failure to register shall not be deemed to create any obligation or liability by the manufacturer and this warranty with its conditions and limitations shall be the only procedure for obtaining any rights against the manufacturer and expresses the sole obligation and responsibilities of the manufacturer which are offered to the original purchaser and accepted upon purchase of the appliance.

Mendota Division, reserves the right to make changes at any time without notice, in design, material, specifications, prices and the right to discontinue styles and products.

Some states do not allow the exclusion of limitation of incidental or consequential damages or limitations on how long an implied warranty lasts, so the above limitation or exclusion may not apply to you. This warranty gives you specific legal rights and you may also have other rights which vary from state to state.



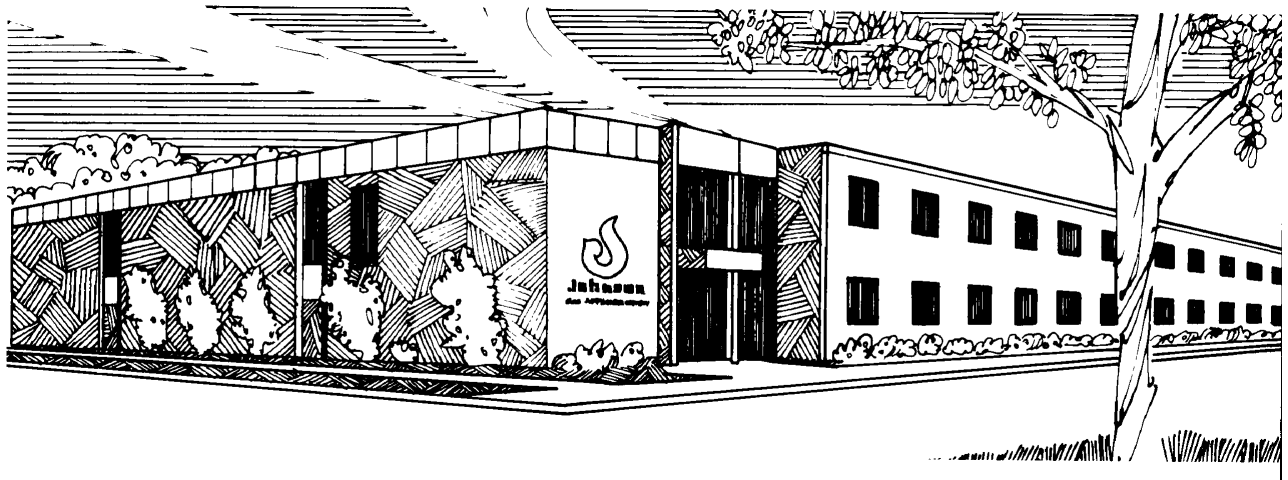

Johnson Gas Appliance Company  
520 E Avenue N.W. - Cedar Rapids, IA 52405  
Mendota Hearth Division

WEBPAGE: [www.johnsongas.com](http://www.johnsongas.com) or [www.mendotahearth.com](http://www.mendotahearth.com)